

TM 9-1595

WAR DEPARTMENT

TECHNICAL MANUAL



ORDNANCE MAINTENANCE

PRISMATIC COMPASS, M1918

July 17, 1941

AUG 23 1941

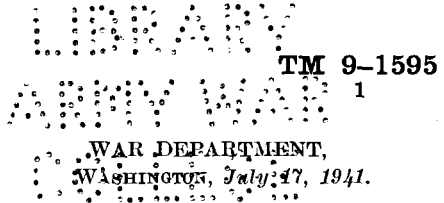

TECHNICAL MANUAL }
No. 9-1595 }

ORDNANCE MAINTENANCE
PRISMATIC COMPASS, M1918

Prepared under direction of the
Chief of Ordnance

SECTION I. General.	Paragraph
Purpose-----	1
Scope-----	2
References-----	3
II. Description.	
Description-----	4
III. Operation and adjustment.	
Operation-----	5
Field test and adjustment-----	6
IV. Inspection.	
Inspection-----	7
V. Maintenance and repair.	
Disassembly and assembly-----	8
Adjustment-----	9
VI. Care and preservation.	
Care and preservation-----	10
APPENDIX. List of references-----	12

*superseded by TM 9-1530
10 Jan. 1945*

SECTION I
GENERAL

Purpose-----	Paragraph
Scope-----	1
References-----	2
	3

1. **Purpose.**—This manual is published primarily for the information and guidance of ordnance maintenance personnel.

1031467
PROPERTY OF U.S.

2. **Scope.**—This manual supplements the technical manuals which are prepared for the using arm. It contains descriptive matter, operating instructions, and detailed instructions for maintenance and repair by ordnance personnel.

3. **References.**—The appendix lists the publications pertaining to the prismatic compass.

SECTION II

DESCRIPTION

Description	Paragraph
-----	4

4. **Description.**—*a.* The prismatic compass is a multiple-purpose instrument for obtaining clinometer, angle of site, and magnetic azimuth readings. It may be used with 155-mm howitzers, M1917, M1918 and modifications; 75-mm guns, M1897, M1897A2, M1917 and modifications; 75-mm pack howitzers, M1 and M1A1; and with other field artillery.

b. The instrument contains a compass dial, B137958, and a clinometer dial, C70112. The clinometer dial carries a lead weight, B137954, which causes it to indicate vertical angles when the instrument is held vertically. In order to make the instrument compact, the clinometer dial is mounted just above the compass dial. A portion of the clinometer dial is cut away so that the compass dial below may be viewed. The compass dial is colored green, and the clinometer dial is white.

c. Folding sights are provided at front and rear. The rear sight, B137950, is hinged to the rear sight slide, B137951, and can be raised or lowered to focus the magnifying prism, A49372, on either the compass dial or the clinometer dial. The function of the prism is to superimpose upon the field, as viewed through the sight, the image of the clinometer or compass dial, so that accurate readings may be taken by using the vane of the front sight as it appears on the image of the dial. The rear sight, assembly, consisting of the leaf sight vane, A49392, and leaf sight vane holder, B137957, is hinged to the front sight bracket, B137959. When turned down, the leaf sight engages the compass lift bar, A49378, which lifts the compass dial from its pivot and clamps it. The dial remains clamped until the leaf sight is opened for operation.

d. A compass dial locking plunger, A49386, protrudes through the case, C70110, near the rear sight, and a similar plunger, A49385, protrudes through the front sight bracket, B137959. When either plunger is pressed, it causes a flat spring, A49387, to bear against the edge of the compass dial, and acts as a brake for damping.

e. The clinometer wedge knob, A49374, when fully depressed clamps the clinometer dial against rotation, and when partially depressed acts as a brake for damping.

f. The plane supporting surface of the case support, B137952, is parallel to the line of sight passing through the front and rear sights.

g. The instrument is furnished complete with carrying case (fig. 3).

h. Prismatic compass, M1918, *without tripod*, and manufactured by the Sperry Gyroscope Company, is a limited standard item for issue by the Ordnance Department. These compasses are graduated in mils and are distinguished from the compasses issued by the Engineer Corps which are graduated in degrees. The tripod previously issued with this item is now not authorized.

SECTION III

OPERATION AND ADJUSTMENT

Operation.....	Paragraph 5
Field test and adjustment.....	6

5. **Operation.**—*a.* To measure angles of site, raise the leaf sight and the rear sight. Pull out the clinometer wedge knob to permit free rotation of the clinometer dial. Focus the rear sight on the clinometer (white) dial, sliding the sight as required. Hold the instrument with the dials in a vertical plane, look through the niche in the rear sight, and elevate or depress the instrument until the object observed is in line with the leaf sight vane. The angle of site, reflected in the rear sight prism, will also be visible in the center of the field of view. The angle of site scale (the outer scale on the clinometer dial) is graduated at 5-mil intervals and numbered at 100-mil intervals; the 50-mil points are also marked. A 300-mil indication corresponds to a level line of sight, as on the corresponding scales of range quadrants. The clinometer wedge knob may be partially depressed to damp out oscillations; it must not be depressed when taking the reading.

b. To measure azimuths, first operate the instrument in angle of site until the compass (green) dial is exposed at the rear sight by the cutaway portion of the clinometer (white) dial. Depress the clinometer wedge knob. Raise the leaf sight and the rear sight. Focus the rear sight on the compass (green) dial, sliding the sight as required. Hold the instrument in the hand or support it on a convenient nonmagnetic body, look through the niche in the rear sight, and rotate the instrument in azimuth until the object observed is in line with the leaf sight vane. The magnetic azimuth, reflected in

the rear sight prism, will also be visible in the center of the field of view. The compass dial is graduated at 10-mil intervals and numbered at 100-mil intervals. Additional numbering is provided in the 3200-6400-mil half of the scale to correspond to the numbering on the azimuth scales of panoramic telescopes which are graduated 0-3200 mils in this range. To damp out oscillations of the compass dial, gently depress one of the locking plungers; plungers must not be in the depressed position when taking the azimuth reading.

c. To use the instrument as a clinometer, pull out the clinometer wedge knob and stand the instrument on its support, prism to the rear, on a straight portion of the piece which is parallel to the bore. The reading of the clinometer scale, at the etched line on the lower window, is the elevation of the piece. The clinometer scale is graduated at 10-mil intervals and numbered at 100-mil intervals. A 300-mil reading indicates the bore of the piece to be level. The sights should not be raised when using the instrument as a clinometer. The clinometer wedge knob may be partially depressed to damp out oscillations; it must not be depressed when taking the reading.

d. To prepare the instrument for traveling, push in the clinometer wedge knob (clamping the clinometer dial) and turn the leaf sight down (clamping the compass dial). Lower and fold back the rear sight. Place the instrument in the leather case provided.

6. **Field test and adjustment.**—Test the alinement of clinometer dial by noting scale readings with instrument on a level reference surface. Scale should read 300 through lower window and through magnifying prism. If scale reading at either point is not correct, note the error and apply necessary correction in subsequent use of the instrument. Corrective adjustment by the using arm is not permitted.

SECTION IV

INSPECTION

Inspection.....	Paragraph 7
-----------------	----------------

7. **Inspection.**—Inspection is for the purpose of determining the condition of the instrument, whether repairs or adjustments are required, and the remedies necessary to insure serviceability and proper functioning. The listing below will serve as a guide for inspection.

<i>Parts to be inspected</i>	<i>Points to be observed</i>
a. General appearance.	a. Note bent or missing parts, loose or missing screws, and condition of window.

PRISMATIC COMPASS, M1918

b. Rear sight, assembly.

b. Try fit of slide and hinge. Parts should operate smoothly, with sufficient friction to remain in position at the operating settings. Motion of slide should be sufficient to permit obtaining clear focus positions for compass dial and clinometer dial.

c. Front sight, assembly.

c. Hinge should operate smoothly with sufficient friction to hold leaf sight in operating position. Vane should be straight and true in vane holder. Compass dial should lock properly when leaf sight is turned down.

d. Clinometer dial.

d. Operate clinometer wedge knob to see that it locks dial when depressed and releases dial when pulled outward. Turn instrument while holding vertically to see that dial operates freely through a complete revolution. Also check with instrument on fixed surface, by releasing dial from several different initial positions; final indication from each position should be the same. If inaccuracies due to friction in the dial movement are noticed in the above tests, instrument requires overhaul.

e. Compass dial.

e. Operate compass dial locking plungers to see that they function properly. Release dial, hold case level and turn so as to check freedom of movement of compass dial. Check accuracy of compass readings by comparison with an instrument of known accuracy; readings should be correct within a tolerance of plus or minus 5 mils. Note time required for compass dial to come to rest; a weak magnetic needle is indicated if dial

Alinement.

takes more than 4 seconds to return to equilibrium position after swinging beyond it.

f. When the compass is leveled, with sights in using position, the rear sight notch and leaf sight vane should be vertical as determined by sighting on a plumb line. Scale readings on clinometer dial should be the same when read through magnifying prism and through lower window opening. Index line in lower window opening should be perpendicular to bearing surface of case support.

SECTION V

MAINTENANCE AND REPAIR

	Paragraph
Disassembly and assembly-----	8
Adjustment -----	9

8. Disassembly and assembly.—Disassembling of the instrument is required only for repair purposes and for the performance of certain adjustments. Complete stripping is not normally required.

a. The rear sight, assembly, and front sight, assembly, are readily accessible for replacement of component parts. The straight pins on which the sights hinge are riveted lightly at each end.

b. The case, assembly, can be opened by removing the two oval head screws, A49391A, which secure the cover, C70111, to the lower case, C70110. (See fig. 2, sec. D-D-D-D.) The three similar screws which secure the clinometer dial support, B137955, are not to be removed at this time. The case support, B137952, can be removed if necessary to permit opening the case, but its position should be marked before removal to insure correct positioning on reassembly. When prying off the cover, be careful to prevent damaging the compass dial, which may fall out of the case. When the case is opened, the upper half will contain the clinometer mechanism and the lower half will contain the compass mechanism, both of which will be accessible for adjustment or further disassembly.

c. To replace the glass window, A49380, remove clinometer dial support, B137955, clinometer dial, assembly, and round nut, A39925. Examine cork pad, A39924, and replace if necessary. Shellac outer

edge of pad to cover and window when assembling. Assemble window with chamfered edge toward pad and with index line in center of clinometer opening. Adjust window to place index line in proper position, as described in paragraph 9*b*(1).

d. Assembling operations are performed in the reverse order of disassembly.

9. Adjustment.—*a. Elimination of excessive friction in compass and clinometer dials.*—No specific adjustment is provided for this purpose. Friction caused by rubbing of the flat spring, A49387, against the compass dial can be removed by bending the spring to provide clearance. Friction on clinometer dial pivot pin can sometimes be removed by bending clinometer support, B137955. If these measures are not successful, replacement of affected parts is required.

b. Alinement.—Complete alinement of the clinometer portion of the instrument is performed in three steps, as follows:

(1) Set index line by turning window, A49380, until clinometer scale reading at index line is same as scale reading through magnifying prism.

(2) Using the sights, read angle of site of a reference point of known angle of site. If reading obtained is not correct, shift lead weight, B137954, on clinometer dial until correct reading is obtained.

(3) Stand the instrument on a level reference surface. Note clinometer scale reading. If reading is not correct, loosen two fillister head screws which secure case support, B137952, and shift case support until correct reading is obtained. Secure case support in this position.

c. Rear sight slide.—Spring, A36657, which bears against rear sight slide, B137951, can be adjusted to provide proper degree of friction in operation of slide.

SECTION VI

CARE AND PRESERVATION

Care and preservation.....	Paragraph 10
----------------------------	-----------------

10. Care and preservation.—*a.* The instrument should be handled carefully to avoid unnecessary shocks. It should be kept in the carrying case when not in use. After use in wet weather, the instrument should be wiped dry before being placed in the carrying case.

b. When the instrument is moved from one position to another, the leaf sight should be turned down to clamp the compass dial and the clinometer wedge knob pushed in to clamp the clinometer dial, thereby preventing injury to the pivots.

c. Particular care should be taken to prevent bending of the leaf sight vane or leaf sight vane holder.

d. Moisture due to condensation may collect in the instrument when the temperature of the parts is lower than that of the surrounding air. This moisture, if not excessive, can be removed by placing the instrument in a warm place.

e. No lubrication is required for this instrument.

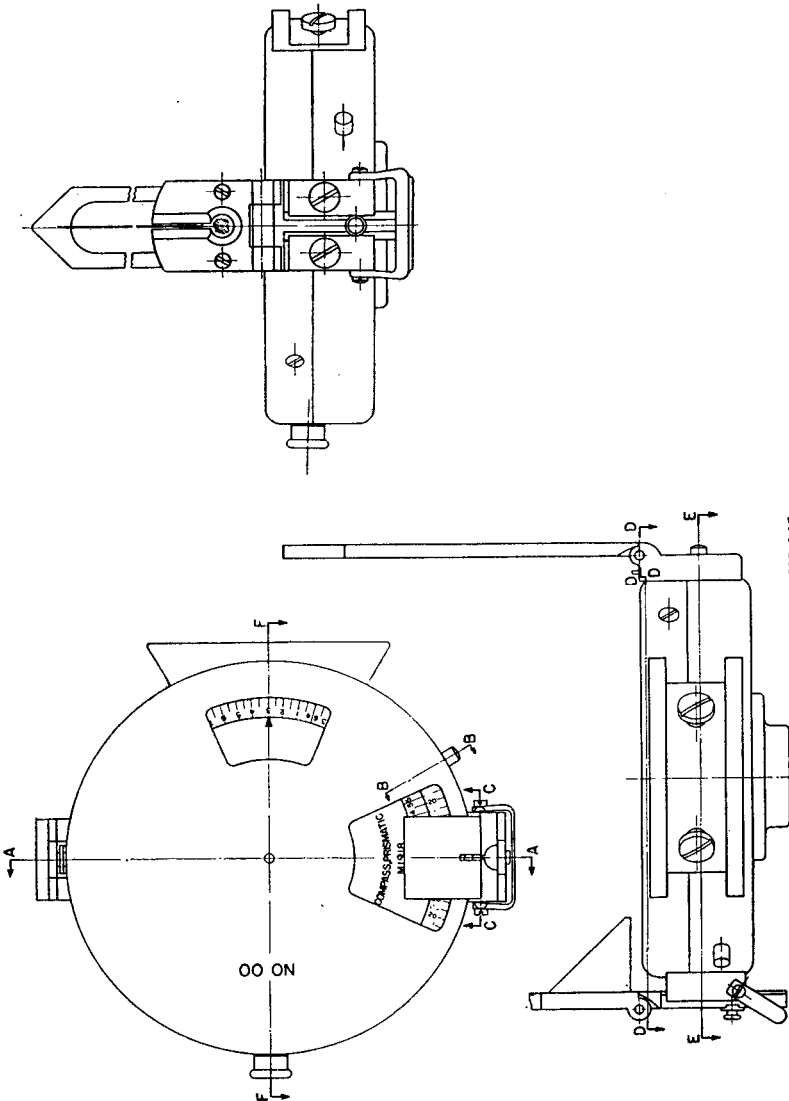

RAFSD 645

FIGURE 1.—Prismatic compass, M1918—assembled views.

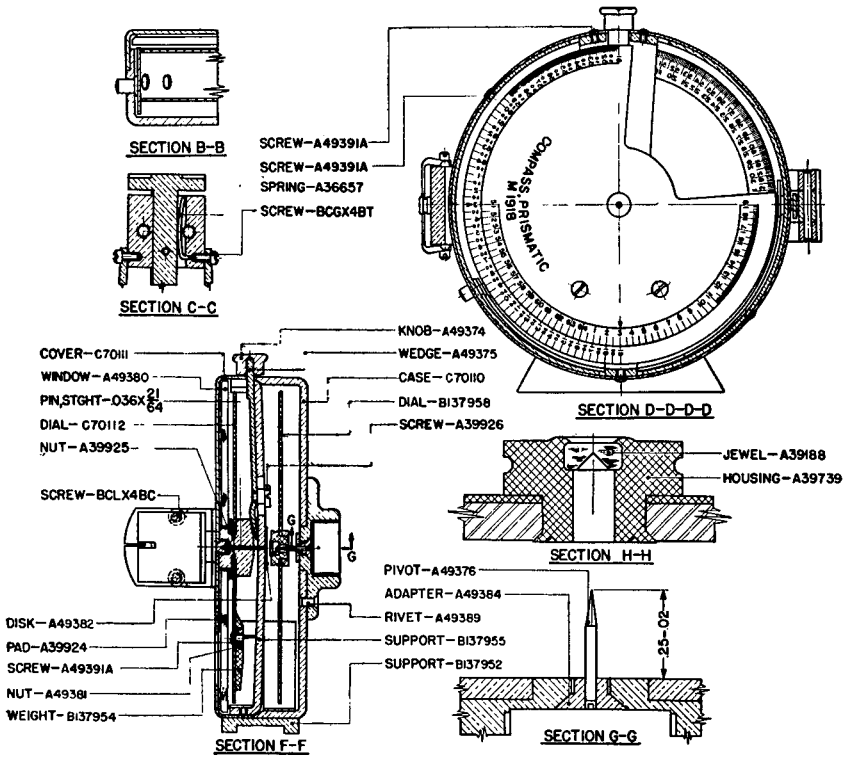

RA PD NEG. #606-JOB #656

FIGURE 2.—Prismatic compass, M1918—sectioned views.

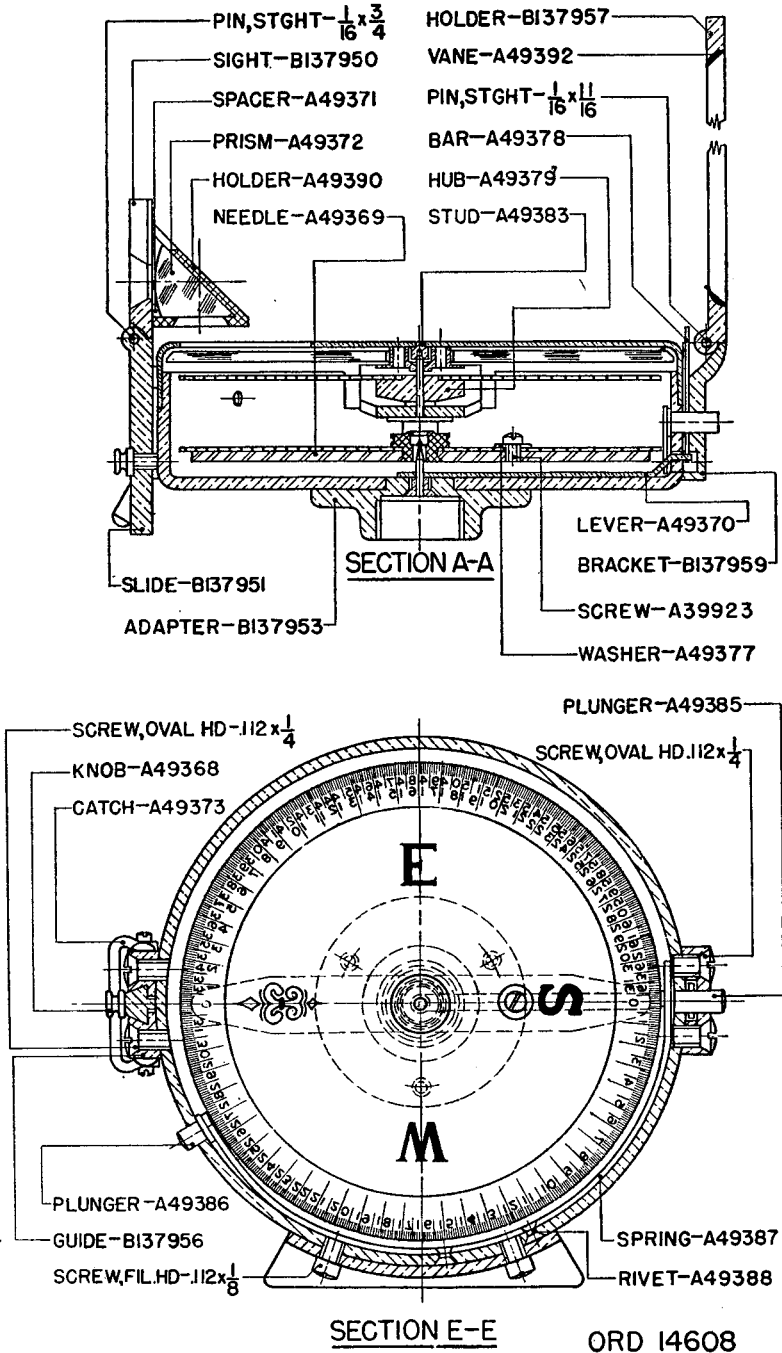
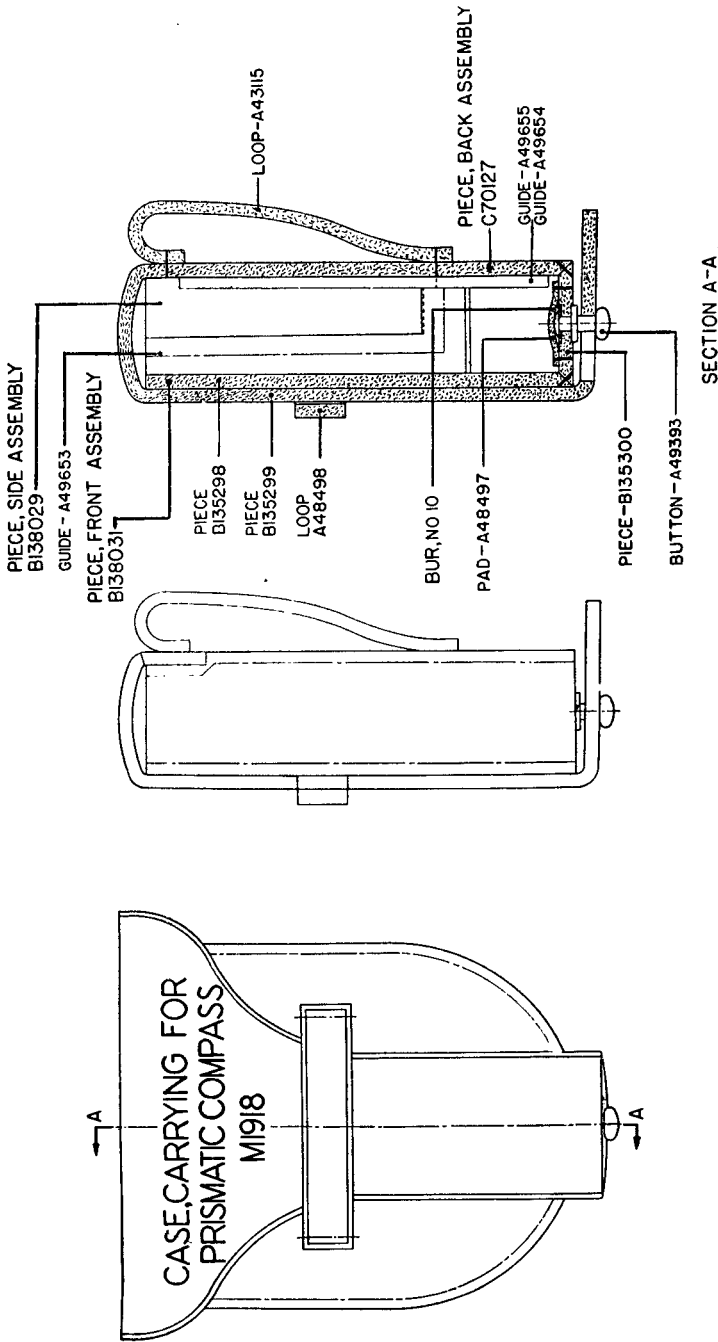

FIGURE 2.—Prismatic compass, M1918—sectional views—Continued.



RA FSD 644

FIGURE 3.—Carrying case for prismatic compass, M1918—assembled and sectional views.

ORDNANCE DEPARTMENT

APPENDIX

LIST of REFERENCES

1. Standard Nomenclature List.

Compass, prismatic, M1918 (Sperry type)----- SNL F-23

2. Technical Manuals.

Matériel inspection and repair----- TM 9-1100

[A. G. 062.11 (5-26-41).]

BY ORDER OF THE SECRETARY OF WAR :

G. C. MARSHALL,
Chief of Staff.

OFFICIAL :

E. S. ADAMS,
Major General,
The Adjutant General.

DISTRIBUTION :

B and H (6) ; R 2, 4-7, 17 (2) ; Bn 9 (2) ; IC 9 (4).
(For explanation of symbols, see FM 21-6.)